

# 1" SQ.DR.EXTRA-DUTY IMPACT WRENCH

EXPLODED VIEW

SP-5000GE

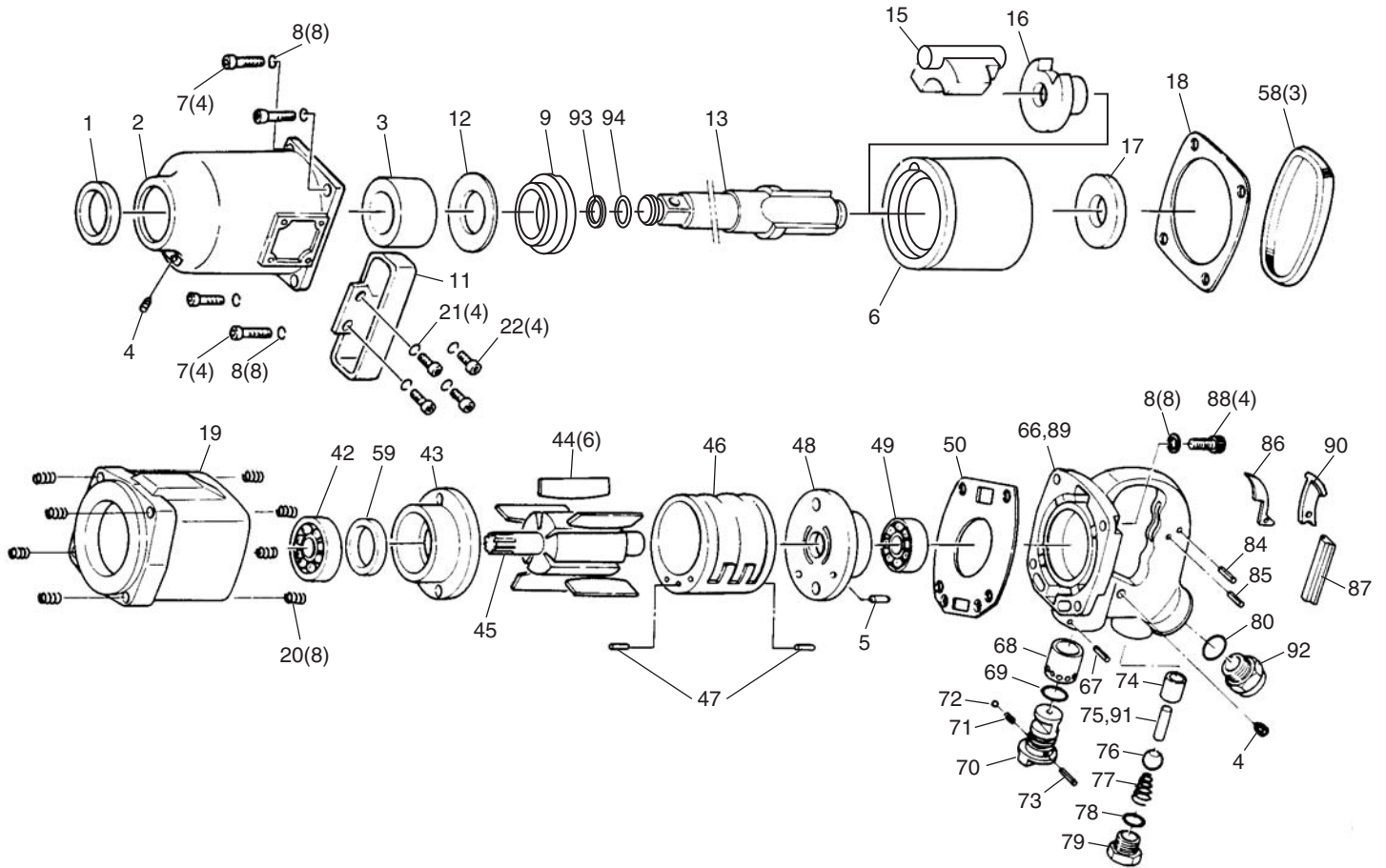

## PARTS LIST

Index No.	Parts No.	Description	Qty. Per tool
1	188GE-01	Oil Seal	1
2	188GE-02	Hammer Case (1,3,4)	1
3	188GE-03	Fixed Bush	1
4	188GE-04	Hex. Screw	2
5	188GE-05	Spring Pin	1
6	188GE-06	Hammer Frame	1
7	188GE-07	Hexagon Socket Bolt	4
8	188GE-08	Spring Washer	8
9	188GE-09	Side Plate	1
11	188GE-11	D-Type Handle	1
12	188GE-12	Thrust Washer	1
13	188GE-13	Anvil (9"Long)	1
15	188GE-15	Hammer	1
16	188GE-16	Cam	1
17	188GE-17	Spacer	1
18	188GE-18	Motor Case Packing	1
19	188GE-19	Motor Case Assy (Incl:20)	1
20	188GE-20	Helically Colled Insert	8
21	188GE-21	Spring Washer	4
22	188GE-22	Hexagon Socket Bolt	4
42	188GE-42	Ball Bearing	1
43	188GE-43	Front End Plate	1
44	188GE-44	Rotor Blade	6
45	188GE-45	Rotor	1
46	188GE-46	Cylinder	1
47	188GE-47	Spring Pin	2
48	188GE-48	Rear End Plate	1
49	188GE-49	Ball Bearing	1
50	188GE-50	Motor Case Packing	1
58	188GE-58	Housing Band	3

Index No.	Parts No.	Description	Qty. Per tool
59	188GE-59	Oil Seal	1
66	188GE-66	Handle Frame Assy (Incl:68,74)	1
67	188GE-67	Roll Pin	1
68	188GE-68	Reverse Bushing	1
69	188GE-69	O-Ring	1
70	188GE-70	Reverse Valve	1
71	188GE-71	Spring	1
72	188GE-72	Steel Ball	1
73	188GE-73	Roll Pin	1
74	188GE-74	Throttle Bushing	1
75	188GE-75	Throttle Pin Inside	1
76	188GE-76	Valve	1
77	188GE-77	Conical Spring	1
78	188GE-78	O-Ring	1
79	188GE-79	Throttle Plug	1
80	188GE-80	O-Ring	1
84	188GE-84	Roll Pin	1
85	188GE-85	Roll Pin	1
86	188GE-86	Throttle Lever Inside	1
87	188GE-87	Rubber Guard	1
88	188GE-88	Hex. Socket Bolt	4
89	188GE-89	Handle Frame Assy (Incl:68,74)	1
90	188GE-90	Throttle Lever Outside	1
91	188GE-91	Throttle Pin Outside	1
92	188GE-92	Inlet Bushing	1
93	188GE-93	Retainer Ring	1
94	188GE-94	O-Ring	1