

# 1/2" REVERSIBLE ANGLE HEAD DRILL

EXPLODED VIEW

SP-1513AH

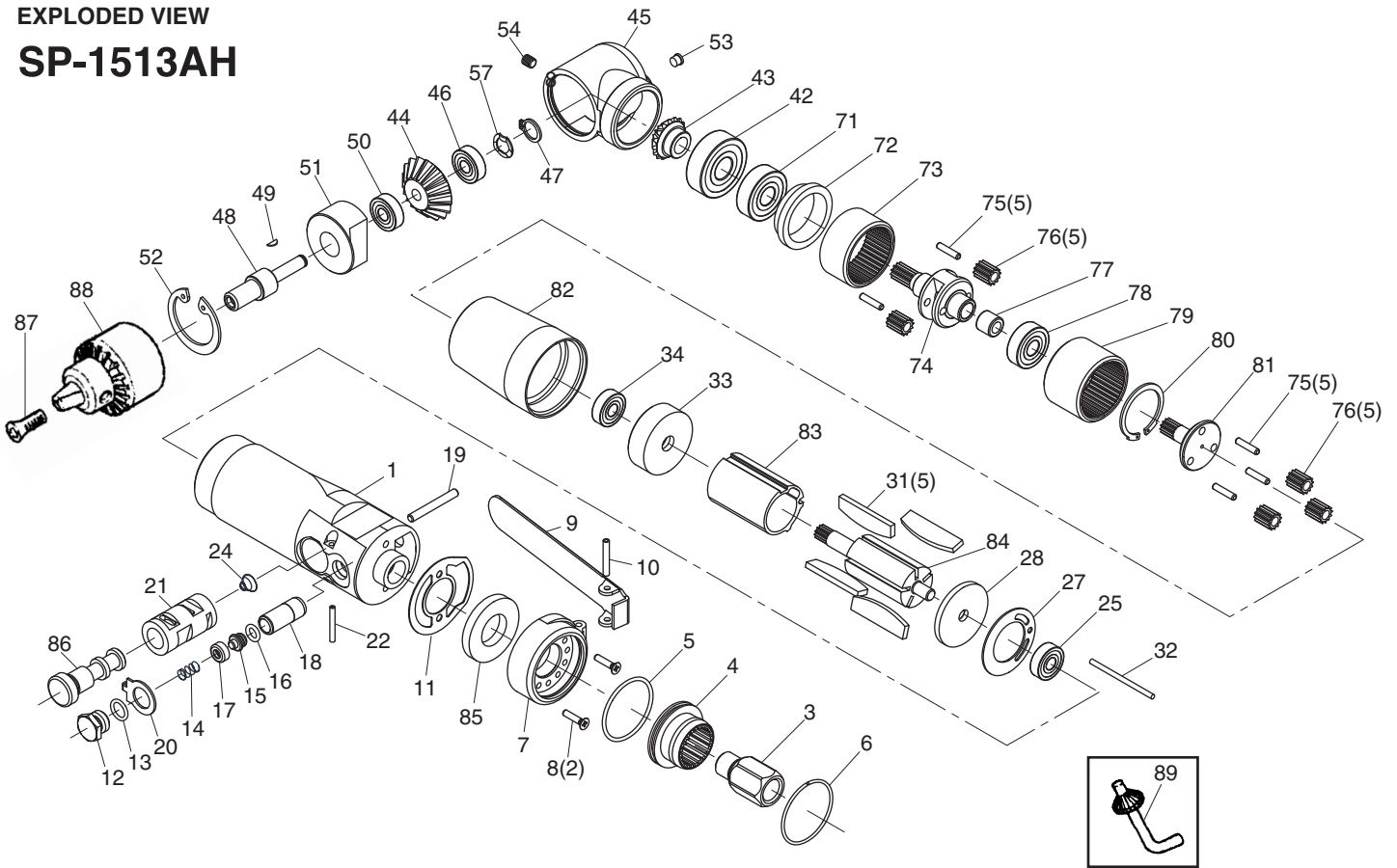

**PARTS LIST**

Index No.	Parts No.	Description	Qty. Per tool
1	510AH-01	Motor Housing Assy (Incl:18,21)	1
3	510AH-03	Inlet Bushing	1
4	510AH-04	Deflector	1
5	510AH-05	O-Ring	1
6	510AH-06	Deflector Stop Ring	1
7	510AH-07	Housing Cap	1
8	510AH-08	Screw	2
9	510AH-09	Throttle Lever	1
10	510AH-10	Spring Pin	1
11	510AH-11	Housing Gasket	1
12	510AH-12	Valve Screw	1
13	510AH-13	O-Ring	1
14	510AH-14	Valve Spring	1
15	510AH-15	Valve	1
16	510AH-16	O-Ring	1
17	510AH-17	O-Ring Retainer	1
18	510AH-18	Valve Bushing	1
19	510AH-19	Valve Pin	1
20	510AH-20	Reverse Retainer	1
21	510AH-21	Reverse Bushing	1
22	510AH-22	Spring Pin	1
24	510AH-24	Reverse Spring	1
25	510AH-25	Ball Bearing	1
27	510AH-27	Motor Gasket	1
28	510AH-28	Rear End Plate	1
31	510AH-31	Rotor Blade	5
32	510AH-32	Motor Pin	1
33	510AH-33	Front End Plate	1
34	510AH-34	Ball Bearing	1
42	510AH-42	Ball Bearing	1
43	510AH-43	Pinion	1
44	510AH-44	Gear	1
45	510AH-45	Angle Housing	1
46	510AH-46	Ball Bearing	1
47	510AH-47	Retainer Ring	1
48	510AH-48	Spindle	1

Index No.	Parts No.	Description	Qty. Per tool
49	510AH-49	Key	1
50	510AH-50	Ball Bearing	2
51	510AH-51	Bearing Case	1
52	510AH-52	Retainer Ring	1
53	510AH-53	Ball Cap	1
54	510AH-54	Set Screw	1
57	510AH-57	Wave Washer	1
71	513AH-71	Ball Bearing	1
72	513AH-72	Spacer	1
73	513AH-73	Internal Gear	1
74	513AH-74	Spindle	1
75	513AH-75	Idle Gear Pin	5
76	513AH-76	Idle Gear	5
77	513AH-77	Needle Bearing	1
78	513AH-78	Ball Bearing	1
79	513AH-79	Internal Gear	1
80	513AH-80	Snap Ring	1
81	513AH-81	Gear Spindle	1
82	513AH-82	Lock Ring	1
83	513AH-83	Cylinder	1
84	513AH-84	Rotor	1
85	513AH-85	Muffler	1
86	513AH-86	Reverse Valve	1
87	513AH-87	Screw	1
88	513AH-88	1/2" Drill Chuck	1
89	513AH-89	Chuck Key	1